



Milan

Das Sitz-System für Fahrer- und Beifahrersitz in Kleinbussen, Transportern und Reisemobilen





Milan

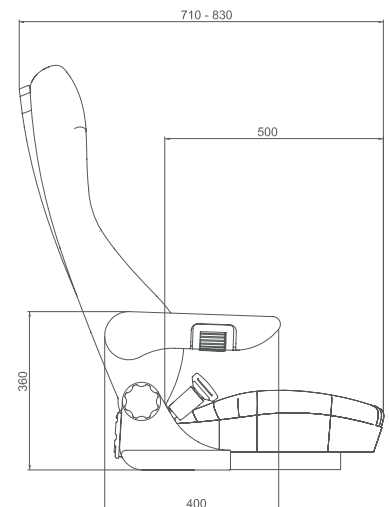
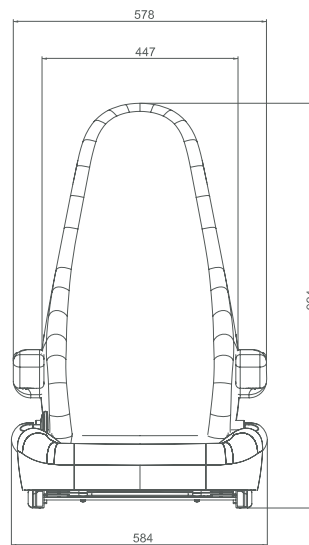

Beschreibung

- Rücken verstellbar
- integrierte Kopfstütze
- TÜV - geprüft M1

Optionen

- neigungsverstellbare Armlehnen
- Gleitschienen
- Dreheinheiten

Anwendungsbereich

Fahrer- und Beifahrersitz in:

- Kleinbussen
- Transportern
- Reisemobilen

TÜV - geprüfte Einbauvarianten



Description

- Adjustable backrest
- Integrated head rest
- TÜV - tested M1

Options

- Adjustable arm rests
- Slide rails
- Turning devices

Areas of use

Driver and passenger seats in:

- minibuses
- vans
- motorhomes

TÜV - tested installation variants



Description

- Dossier réglable
- Appui-tête intégré
- Testé M1 - TÜV

Exécutions

- Accoudoir inclinable
- Rail coulissant
- Système pivotant

Champ d'application

Siège conducteur et accompagnant pour:

- minibus
- transporteurs
- camping cars

Aménagements testés au TÜV