

# SOLLEVATORI DOPPIO BRACCIO "BBW 1030 LIGHT - BBW 1350"



Le BBW-1030-LIGHT e BBW-1350 sono sponde doppio braccio completamente automatiche con pedane ripiegate verticalmente, semplice nell'uso, e, adatte al montaggio interno per una vasta gamma di veicoli adibiti al trasporto di persone.

- Piattaforma a griglia antiscivolo scomponibile verticalmente che permette passaggio e ampia visuale.
- Funzionamento elettroidraulico con azionamento di due cilindri oleodinamici.
- Movimentazione effettuata tramite pulsantiera a due tasti.
- Ribaltine di sicurezza sulla piattaforma di carico sia anteriormente che posteriormente.
- Sicurezza antiribaltamento.
- Pompa ausiliaria di emergenza.



*The BBW-1030-LIGHT and BBW-1350 are twin arm lifts, completely automatic with split platform. They can be mounted internally in a wide range of vehicles for people transportation.*

- Platform with anti-slip surface, when stowed it folds horizontally in half, which allows a good view.
- Safety-stop-plates for the wheel chair, placed on the front and back of the platform.
- Powered through an electro-hydraulic unit and 2 cylinders.
- Controlled through a 2 button pendant switch.
- Anti-tilting safety device.
- Auxiliary emergency hand pump.

## SOLLEVATORI DOPPIO BRACCIO "BBW 1030 LIGHT - BBW 1350"

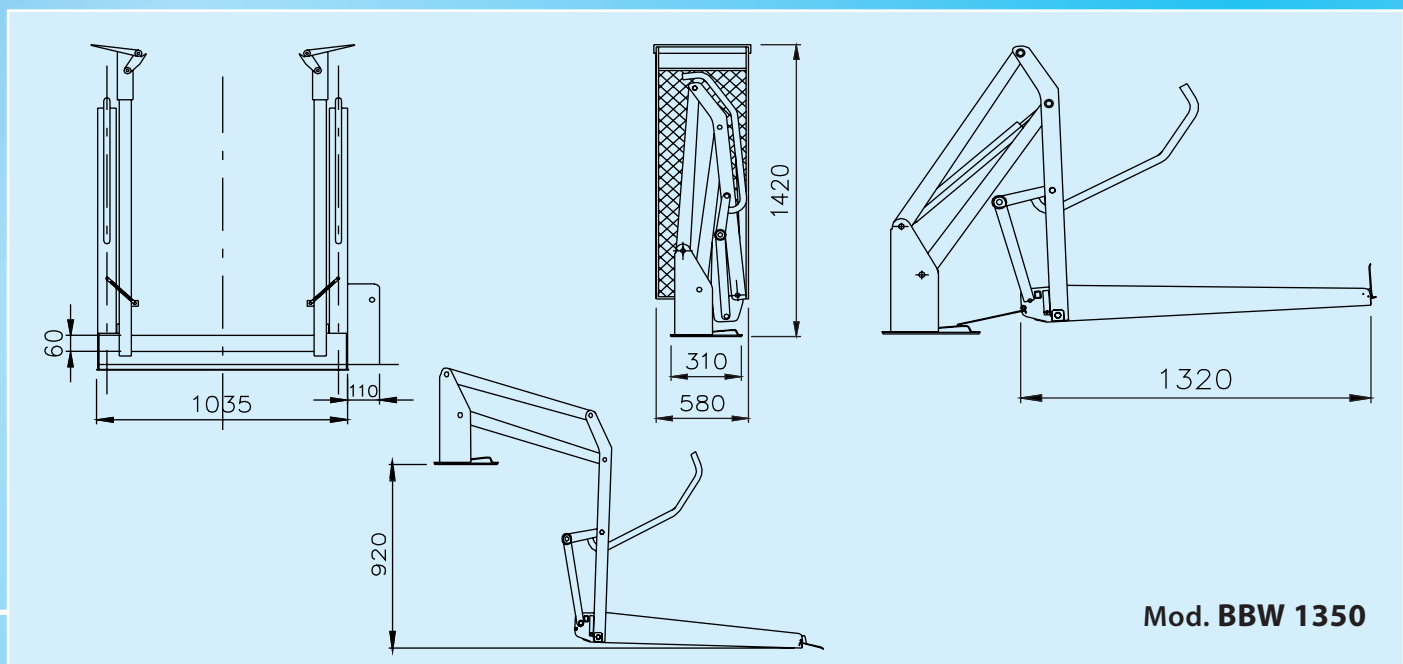
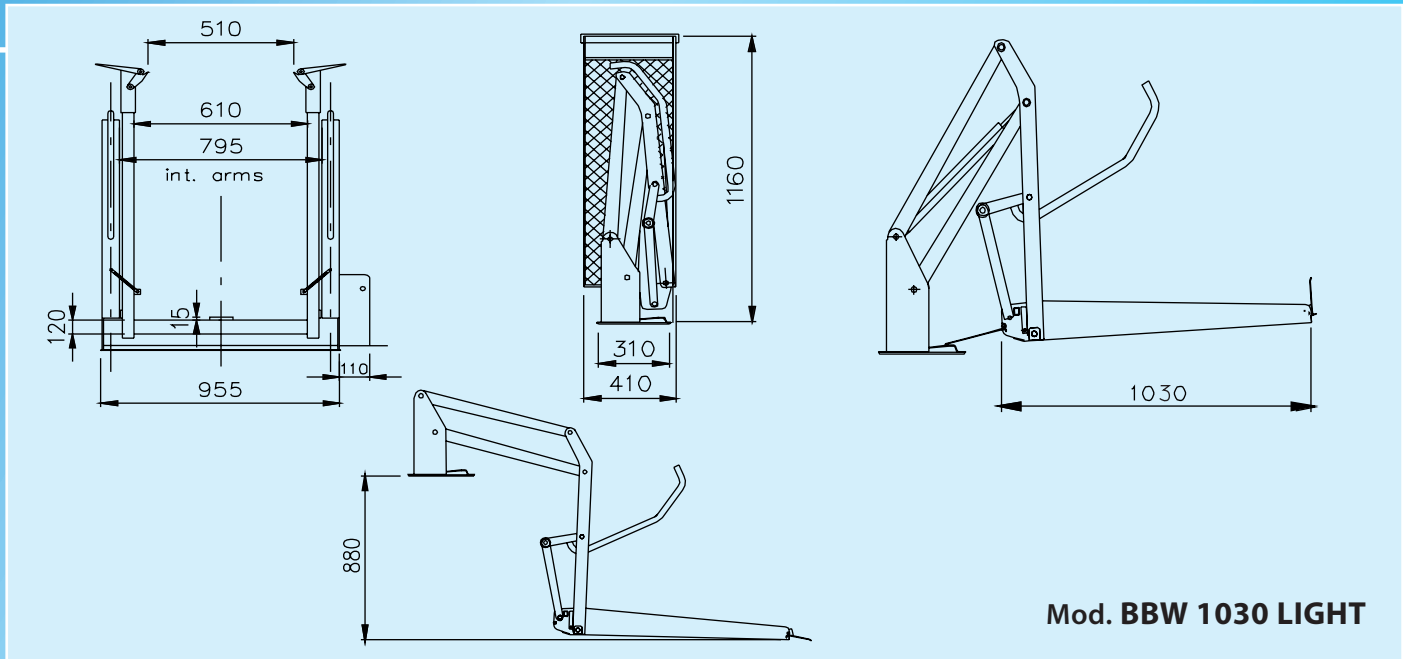

### **Dati Tecnici**

Modello	BBW 1030 LIGHT	BBW 1350
Portata	320 kg	350 kg
Tara	110 kg	145 kg
Alimentazione	12-24 Volt	12-24 Volt
Pressione Max	140 Bar	140 Bar
Piattaforma	1030x740 mm	1350x800 mm
Altezza elevabile	880 mm	920 mm
Pompa ausiliaria di emergenza		

### **Technical Features**

Model	BBW 1030 LIGHT	BBW 1350
Loading capacity	320 kg	350 kg
Own weight	110 kg	145 kg
Electrical System	12-24 Volt	12-24 Volt
Max Pressure	140 Bar	140 Bar
Platform Dimension	1030x740 mm	1350x800 mm
Max. Floor Height	880 mm	920 mm
Emergency auxiliary manual pump.		